



FUSION

34MM FORK SET UP GUIDE



STEP 1: INSTALL 34MM STANCHION TUBE FORK

MAKE SURE THAT THE FORK IS INSTALLED CORRECTLY. IF DO NOT KNOW HOW TO PROFESSIONALLY INSTALL YOUR FORK, PLEASE CONTACT YOUR LOCAL BIKE SHOP FOR ASSISTANCE. ALWAYS CHECK TO MAKE SURE YOUR STEM, HEADSET, HANDLEBARS AND FRONT WHEEL AXLE ARE TIGHTENED TO THE MANUFACTURER'S SPECIFICATIONS.

STEP 2: SETTING SAG

SAG IS THE AMOUNT OF TRAVEL THE FORK COMPRESSES UNDER NORMAL RIDER WEIGHT. WE RECOMMEND THAT YOU SET YOUR FORK SAG AT 25-30%, BUT PERSONAL PREFERENCE AND RIDING CONDITIONS ARE ALSO FACTORS INFLUENCING THE AMOUNT OF SAG NEEDED.

TO CHECK SAG:

- 1) GET ALL OF YOUR GEAR ON, SO YOU START WITH AN ACCURATE RIDER WEIGHT
- 2) WITH SOMEONE HOLDING THE BIKE BY THE HANDLEBARS, STAND UP ON THE PEDALS AND GET IN YOUR NORMAL RIDING POSITION ON THE BIKE.
- 3) BOUNCE UP AND DOWN ON THE BIKE, COMPRESSING THE FRONT FORK, AND WHEN YOU ARE STEADY AGAIN, HAVE SOMEONE PUSH THE TRAVEL RING UP THE STANCHION TUBE AGAINST THE WIPER SEAL.
- 4) DISMOUNT THE BIKE GENTLY (SO YOU DON'T MOVE THE TRAVEL RING).
- 5) THE AMOUNT OF STANCHION SHOWN BETWEEN THE WIPER AND TRAVEL RING IS YOUR SAG. 30% SAG WOULD SHOW 42MM OF EXPOSED STANCHION BETWEEN THE WIPER AND TRAVEL RING ON THE 140MM FORK.

ALL 34MM FORKS USE AN AIR SPRING, AND TO ALTER THE SAG, YOU MUST SIMPLY USE THE AIR PUMP THAT COMES WITH YOUR FORK, OR ANY OTHER HIGH-PRESSURE SHOCK/FORK PUMP.

PLEASE CHECK THE SPRING RATE DOCUMENT ON THIS WEB PAGE FOR THE LATEST INFORMATION ON SUGGESTED SPRING PRESSURES.



STEP 3: REBOUND DAMPING

THE REBOUND ADJUSTER ON ALL 34MM FORKS IS LOCATED AT THE BOTTOM OF THE RIGHT FORK LEG.

-TURNING THE RED ADJUSTMENT KNOB CLOCKWISE (LOOKING AT THE BOTTOM OF THE FORK) WILL SLOW DOWN THE REBOUND (RETURN SPEED)

-TURNING THE RED ADJUSTMENT KNOB COUNTER-CLOCKWISE WILL SPEED UP THE REBOUND (RETURN SPEED)

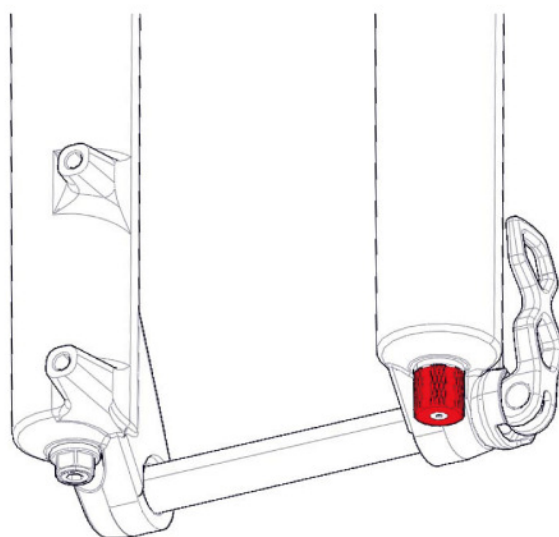

PERSONAL PREFERENCE AND TERRAIN ARE FACTORS IN YOUR REBOUND SETUP, BUT YOU SHOULD STILL TAKE A FEW THINGS INTO ACCOUNT.

- YOU DO NOT WANT YOUR REBOUND SO SLOW THAT THE FORK CAN'T REACT TO THE NEXT IMPACT ON TRAIL.

- YOU ALSO DO NOT WANT THE FORK TO REBOUND SO FAST IT COULD UNEXPECTEDLY SEND YOU OFF BALANCE OR EVEN OFF THE BIKE.

DURING INITIAL SET-UP, WE RECOMMEND STARTING WITH THE BASE SETTING AND ADJUSTING ACCORDINGLY FROM THERE. HERE IS HOW TO FIND YOUR CORRECT REBOUND SETTING.

- 1) TURN THE REBOUND KNOB ALL THE WAY CLOCKWISE UNTIL IT REACHES THE END OF THE ADJUSTMENT. THIS SETTING IS THE SLOWEST RETURN SETTING.
- 2) TURN THE ADJUSTMENT KNOB 8 CLICKS COUNTER CLOCKWISE. THIS WILL SET YOU AT YOUR BASE REBOUND SETTING IN THE MIDDLE OF THE RANGE. (THERE ARE APPROXIMATELY 16 CLICKS OF ADJUSTMENT).



RC KNOBS

BLUE KNOB:

LOW SPEED COMPRESSION, CLOCKWISE
FROM BOTTOM (IN) TO INCREASE

GRAY CAP: DUST COVER ONLY

HIGH AND LOW SPEED DAMPING EXPLAINED

HIGH AND LOW SPEED REFERS TO THE SHAFT VELOCITY OF THE SHOCK ABSORBER. IT IS NOT NECESSARILY RELATED TO THE SPEED OF THE BICYCLE, OR THE SIZE OF THE BUMP. FOR EXAMPLE, A SMALL SHARP BUMP STILL ACTIVATES THE HIGH-SPEED COMPRESSION ADJUSTMENT. A LONG, LARGE GRADUAL BUMP (LIKE THE FACE OF A JUMP) ACTIVATES THE LOW SPEED COMPRESSION CIRCUITS. THE LOW SPEED COMPRESSION ADJUSTER AFFECTS RIDE HEIGHT, SMOOTHNESS OVER SMALL BUMPS AND TIRE GRIP. THE HIGH-SPEED COMPRESSION ADJUSTER AFFECTS STABILITY, FIRMNESS ON DROPS AND FAST CORNERS.

LOW SPEED COMPRESSION ADJUSTMENT

LOW-SPEED COMPRESSION (LSC) CONTROLS THE RATE THE FORK COMPRESSES UNDER SLOWER SHAFT SPEEDS. THESE TYPES OF IMPACTS ON THE FORK CAN BE CAUSED BUT NOT LIMITED TO SMALL BUMPS, CORNERING FORCES, JUMP TAKE-OFFS, PEDALING FORCES AND EVEN BRAKING FORCES. LSC AFFECTS YOUR SMALL BUMP SENSITIVITY AND INITIAL STROKE FIRMNESS. THERE ARE ABOUT 13 CLICKS OF LSC ADJUSTMENT.

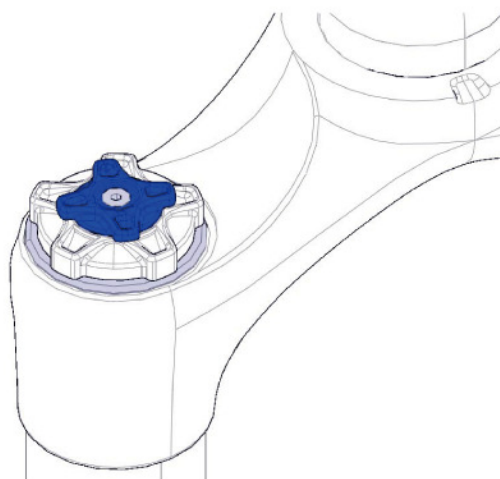

LSC TIP: IF YOU FEEL LIKE THE FORK IS COMPRESSING TOO MUCH DURING BRAKING OR WHEN YOU ARE PEDALING, TURN THE ADJUSTER IN. WHEN ADJUSTING THE LSC, ALWAYS MOVE 2 CLICKS AT A TIME IN EITHER DIRECTION. IF THE CHANGE IS TOO MUCH, THEN BACKTRACK ONE CLICK.



3) ONCE YOU ARE AT THIS BASE SETTING, PEDAL AROUND AND DETERMINE IF YOU NEED TO SLOW DOWN OR SPEED UP YOUR REBOUND. WHEN ADJUSTING THE REBOUND, ALWAYS MOVE 2 CLICKS AT A TIME IN EITHER DIRECTION. IF THE CHANGE IN REBOUND SPEED IS TOO MUCH, THEN BACK-TRACK ONE CLICK. THIS IS A QUICK AND EFFICIENT WAY TO FIND THE CORRECT SETTING.

NOTE: WITH REBOUND DAMPING SET-UP, YOU ARE LOOKING FOR THE SETTING THAT PROVIDES THE BEST BALANCE BETWEEN TOO FAST AND TOO SLOW. IT SHOULD BE INTUITIVE THE “JUST RIGHT” SETTING, SO TRUST YOUR INSTINCTS.

STEP 4: COMPRESSION DAMPING

RL2 KNOBS

BLUE KNOB:

OPEN AND LOCKOUT POSITIONS ONLY

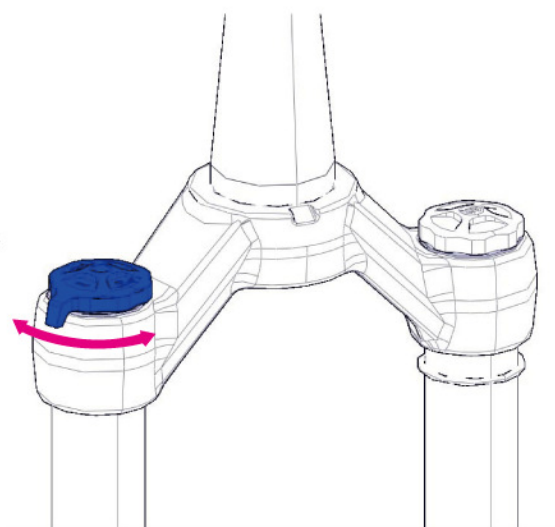

HLR KNOBS

BLUE KNOB:

LOW SPEED COMPRESSION,
CLOCKWISE (IN) TO INCREASE

GOLD KNOB:

HIGH SPEED COMPRESSION,
CLOCKWISE (IN) TO INCREASE

GRAY CAP:

DUST COVER ONLY ON NON-
ROUGH CUT MODELS

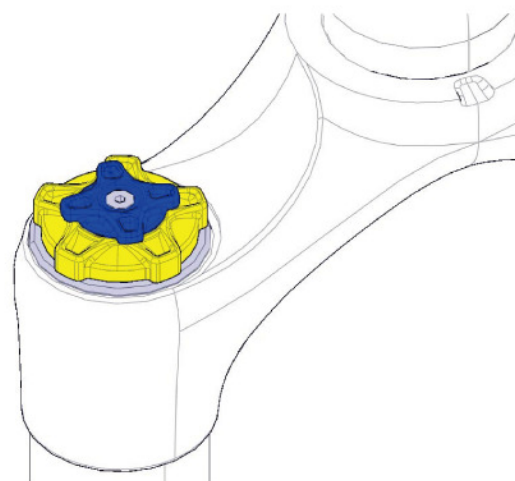



HIGH SPEED COMPRESSION ADJUSTMENT (HLR MODEL ONLY)

HIGH-SPEED COMPRESSION (HSC) CONTROLS THE RATE THE FORK COMPRESSES UNDER FAST SHAFT SPEEDS AND BIG IMPACTS. THESE TYPES OF IMPACTS CAN BE CAUSED BUT NOT LIMITED TO DROPS, BIG JUMPS, LARGE BUMPS AND SQUARE EDGE HITS. BY SETTING YOUR HIGH-SPEED ADJUSTMENT TO FIRMER SETTINGS, YOU CAN SLOW DOWN THE RATE THE FORK COMPRESSES DURING THESE FORCES. THERE ARE ABOUT 15 CLICKS OF HSC ADJUSTMENT.

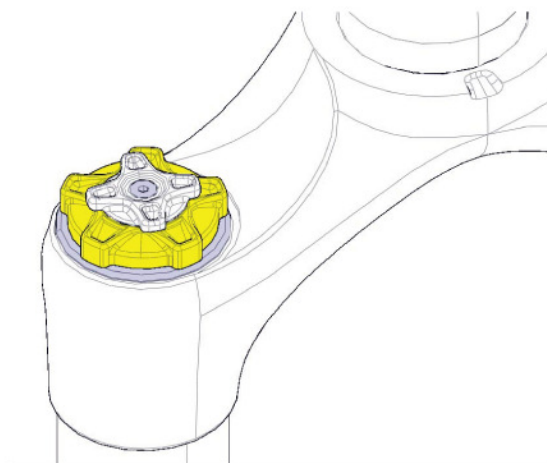

HSC TIP: IF YOU FEEL LIKE THE FORK IS “SPIKING” OR FEELING HARSH DURING FAST, HIGH SPEED IMPACTS TURN THE ADJUSTER OUT A FEW CLICKS. IF YOU FEEL LIKE THE FORK IS GOING TO BOTTOM OUT TOO QUICKLY, TURN THE ADJUSTER IN A FEW CLICKS. WHEN ADJUSTING THE HSC, ALWAYS MOVE 2 CLICKS AT A TIME IN EITHER DIRECTION. IF THE CHANGE IS TOO MUCH, THEN BACKTRACK ONE CLICK.

NOTES

IT IS NORMAL FOR A SLIGHT GREASE RING TO FORM AROUND THE STANCHIONS AFTER EVERY RIDE. THE GREASE IS USED AS LUBRICATION TO IMPROVE THE LONGEVITY AND SMOOTHNESS OF YOUR FORK’S DUST WIPERS. IT’S BEST TO WIPE THE GREASE RING AWAY AFTER EVERY RIDE TO AVOID CONTAMINANTS ENTERING YOUR FORK UNDER THESE SEALS. IF EXCESSIVE AMOUNTS OF OIL BEGINS LEAKING FROM ANYWHERE ON YOUR FORK THEN PLEASE CONTACT YOUR LOCAL BIKE SHOP OR X-FUSION AUTHORIZED SERVICE CENTER.

- NEVER USE A HIGH-PRESSURE WASHER WHEN CLEANING YOUR FORK!
- USE A SOFT SCRUB BRUSH AND WARM SOAPY WATER WHEN CLEANING YOUR FORK.

SERVICE

-WE RECOMMEND YOUR FORK RECEIVE STANDARD DAMPER AND LOWER LEG SERVICE AFTER EVERY 80 HOURS OF RIDE TIME OR ANNUALLY, WHICHEVER IS FIRST. THIS SERVICE SHOULD BE PERFORMED ONLY BY AN EXPERIENCE SUSPENSION TECHNICIAN